

DCS-1600/C2

Published:04/11/2018

TABLE OF CONTENTS

MOTOR	1
CHAIN BRAKE.....	3
ACCESSORIES.....	5

MOTOR

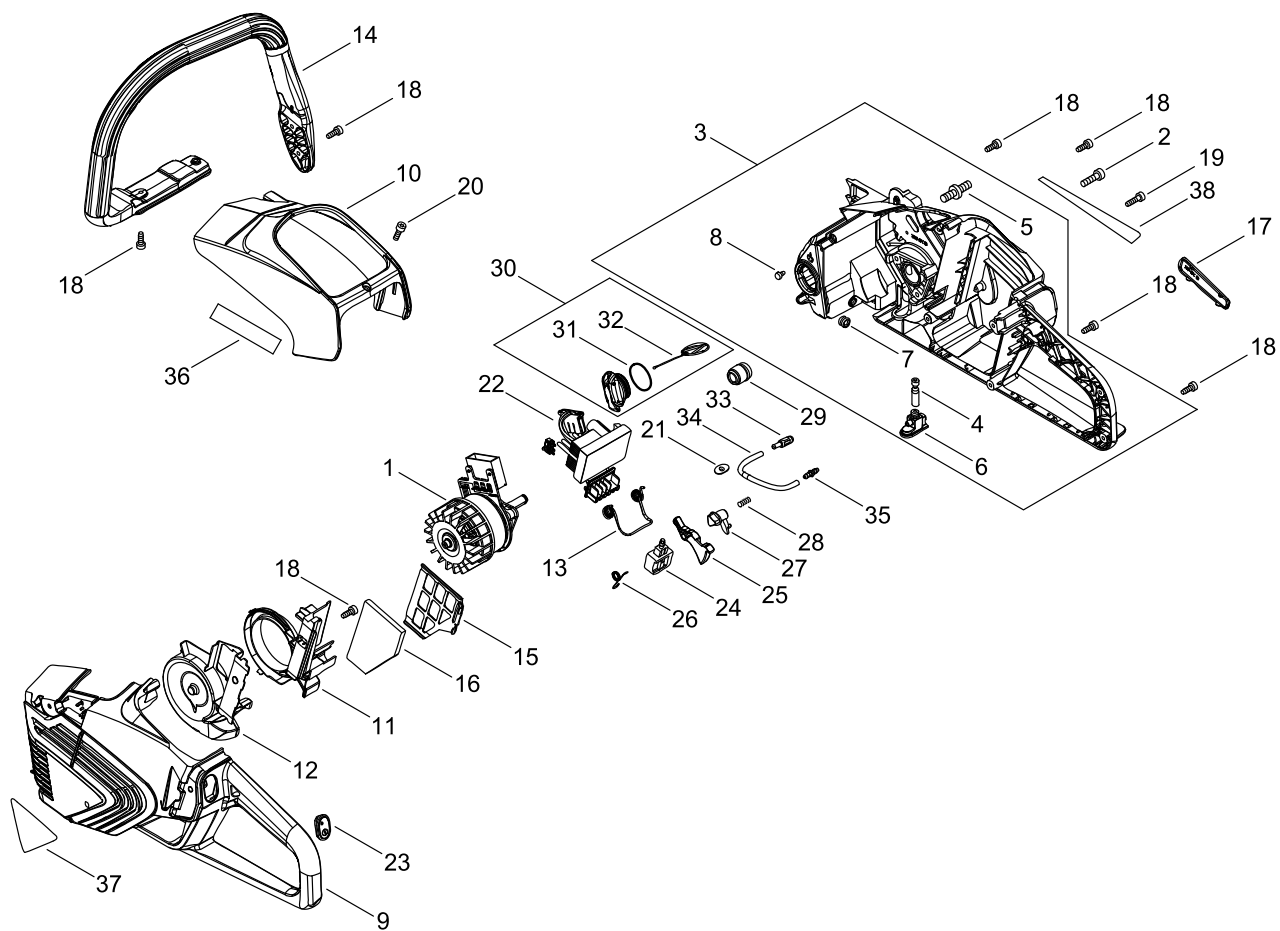

MOTOR

KEY NO	LV(+)	Part No	Description	Qty	Standard	Comment
1		A054-000290	MOTOR,ASM	1		
2		V805-000160	BOLT, TORX 5	3	TB-5*20 10.9	
3		P100-004470	COVER,MOTOR ASY	1		
4	+	C022-000072	AUTO-OILER ASSEMBLY	1		
5	+	V225-000370	BOLT,STUD 8	2	M8	
6	+	V470-002350	PIPE	1		
7	+	132115-01461	GROMMET	1		
8	+	A356-000130	VALVE,CHECK	1		
9		A539-000440	COVER,MOTOR	1		
10		J470-008660	COVER	1		
11		E103-001520	CASE,FAN	1		
12		E103-001530	CASE,FAN	1		
13		V452-001790	SPRING,TORSION	1		
14		C400-001650	HANDLE, FRONT	1		
15		A232-001960	LID,CLEANER	1		
16		A226-002180	ELEMENT, AIR FILTER	1		
17		C412-000740	GRIP, HANDLE	1		
18		V804-000010	BOLT, TORX 4	11	TT-4*16 DG 10.9	
19		V804-000020	BOLT, TORX 4	1	TT-4*20 DG 10.9	
20		V804-000060	BOLT, TORX 4	1	TB-4*16 10.9	
21		V280-000000	NUT,WELD	1	M4	
22		A047-000380	BOARD,ASM CONTROL	1	120A	
23		A047-000390	BOARD,ASM CONTROL	1		
24		G334-001830	SWITCH	1	G33407S0080	
25		J361-000760	LEVER	1		
26		V452-001780	SPRING,TORSION	1		
27		C490-000000	LOCKOUT	1		
28		V450-002250	SPRING,COMPRESSION	1		
29		V652-000250	GEAR,WORM	1		
30		P100-004480	CAP ASY	1		
31	+	900720-20029	O-RING 29	1	P-29	
32	+	A365-000050	CONNECTOR,CAP	1		
33		P100-001900	STRAINER, OIL	1		
34		V471-002380	PIPE	1		
35		V186-000510	JOINT,PIPE	1		
36		X502-001060	LABEL,ECHO	1		
37		X543-005090	LABEL,MODEL	1		
38		X505-010220	LABEL,CAUTION	1		

CHAIN BRAKE

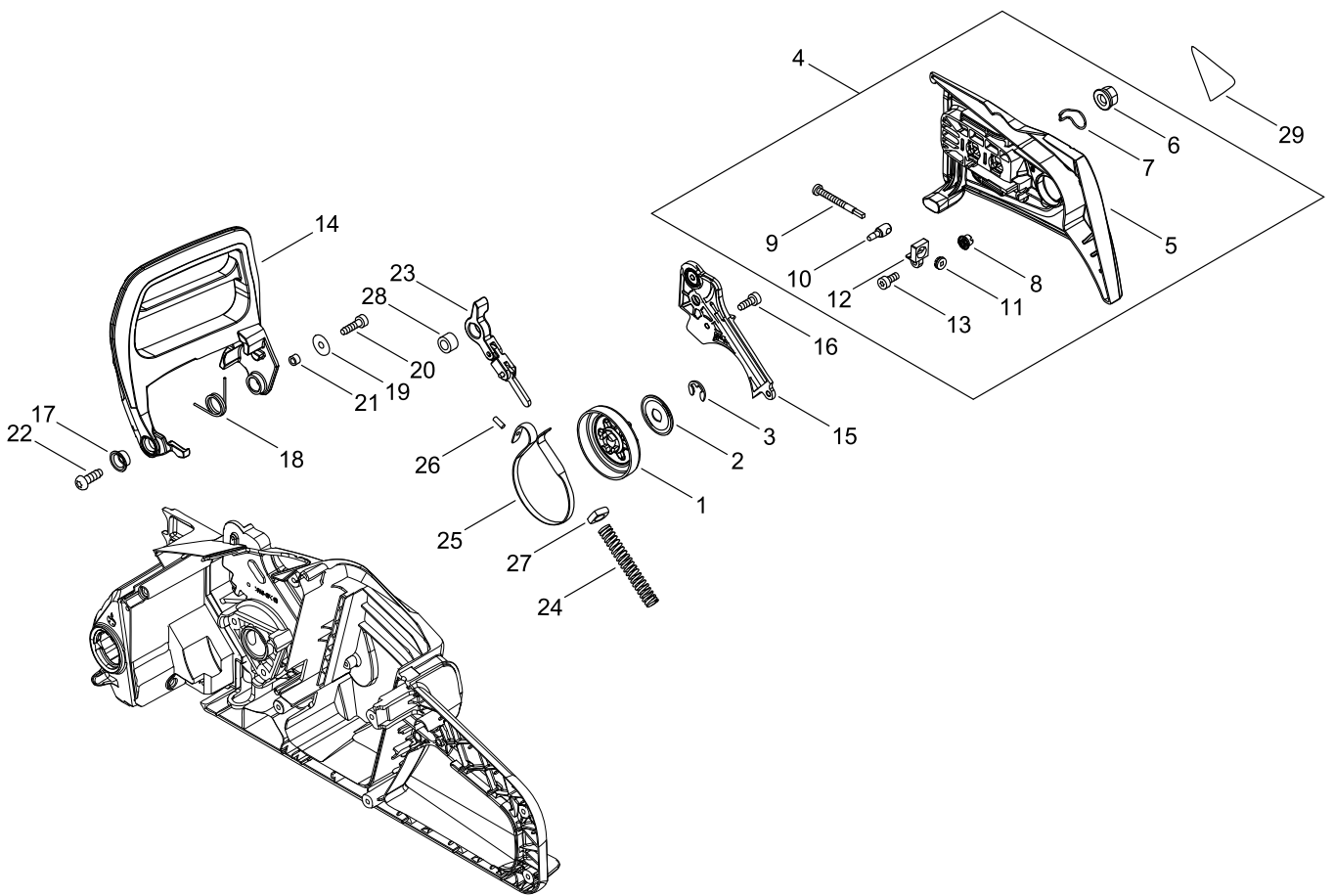

CHAIN BRAKE

KEY NO	LV(+)	Part No	Description	Qty	Standard	Comment
1		A556-001800	DRUM, CLUTCH	1	3/8	
2		V307-000520	WASHER,CIRCULAR 10	1		
3		V583-000440	RING	1	8.1 T1.2	
4		P100-004490	GUARD, SPROCKET ASY	1		
5	+	C300-001170	GUARD, SPROCKET	1		
6	+	V265-000550	NUT,8	2		
7	+	C649-000420	HOOK	2		
8	+	C309-000030	TENSIONER,CHAIN	1		
9	+	V203-000041	BOLT,5	1		
10	+	V651-001060	GEAR,BEVEL	1		
11	+	V651-000011	GEAR,BEVEL	1		
12	+	V355-000900	COLLAR,8	1		
13	+	V804-000000	BOLT, TORX 4	1	TT-4*12 DG 10.9	
14		C320-000540	LEVER, BRAKE	1		
15		C345-000670	COVER,BRAKE	1		
16		V804-000010	BOLT, TORX 4	3	TT-4*16 DG 10.9	
17		V356-000430	COLLAR,10	1		
18		V452-000250	SPRING,TORSION	1		
19		177214-03930	WASHER	1		
20		V804-000020	BOLT, TORX 4	1	TT-4*20 DG 10.9	
21		433116-35430	SPACER 8	1	8*12*9	
22		V805-000010	BOLT, TORX 5	1	TT-5*20 DG 10.9	
23		C334-000100	CONNECTOR, BRAKE	1		
24		V450-002240	SPRING,COMPRESSION	1		
25		C328-000340	BAND, BRAKE	1		
26		93050-30098	ROLLER	1	F3*9.8	
27		V376-000450	SPACER	1		
28		433116-35430	SPACER 8	1	8*12*9	
29		X502-001070	LABEL,ECHO	1		

ACCESSORIES

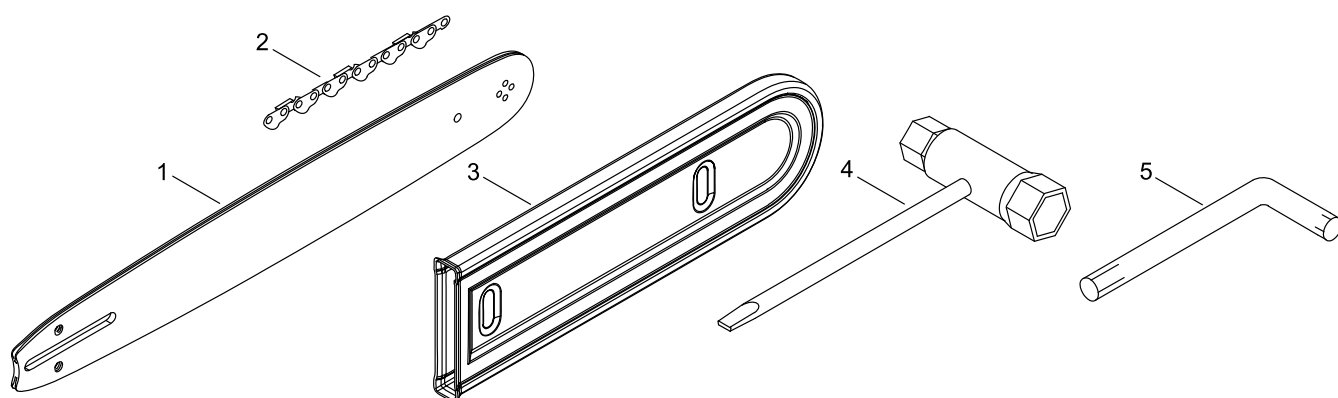

LBP-560-200

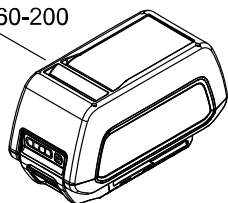
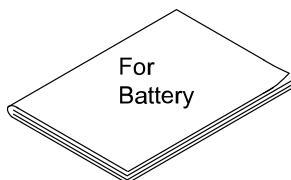
For
Battery

LCJQ-560C

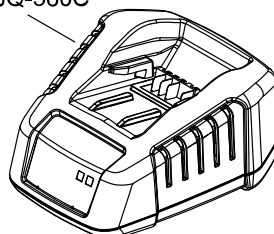
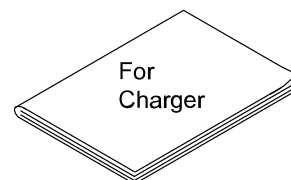
For
Charger

* Batteries and charger are handle
as accessories instead of spare parts.
Please place an order of batteries and charger
at the same time as unit order.

ACCESSORIES

KEY NO	LV(+)	Part No	Description	Qty	Standard	Comment
1		X123-000231	BAR,GUIDE 35	1	C35S90-52SA-ET	
2		X223-000150	CHAIN,SAW	1	90PX-52E	
3		X490-000510	SCABBARD,CHAIN	1		
4		X602-000080	TOOL,WRENCH	1	13*19 L180	
5		X605-000170	TOOL,L WRENCH	1		

NUMERICAL PARTS INDEX

Part No	Part description	Page	Part No	Part description	Page	Part No	Part description	Page
132115-0-1461	GROMMET	2	C649-00-0420	HOOK	4	V470-00-2350	PIPE	2
177214-0-3930	WASHER	4	E103-00-1520	CASE,FAN	2	V471-00-2380	PIPE	2
433116-3-5430	SPACER 8	4	E103-00-1530	CASE,FAN	2	V583-00-0440	RING	4
900720-2-0029	O-RING 29	2	G334-00-1830	SWITCH	2	V651-00-0011	GEAR,BEVEL	4
93050-30-098	ROLLER	4	J361-00-0760	LEVER	2	V651-00-1060	GEAR,BEVEL	4
A047-00-0380	BOARD,ASM CONTROL	2	J470-00-8660	COVER	2	V652-00-0250	GEAR,WORM	2
A047-00-0390	BOARD,ASM CONTROL	2	P100-00-1900	STRAINER, OIL	2	V804-00-0000	BOLT, TORX 4	4
A054-00-0290	MOTOR,ASM	2	P100-00-4470	COVER,MOTOR ASY	2	V804-00-0010	BOLT, TORX 4	2
A226-00-2180	ELEMENT, AIR FILTER	2	P100-00-4480	CAP ASY	2	V804-00-0010	BOLT, TORX 4	4
A232-00-1960	LID,CLEANER	2	P100-00-4490	GUARD, SPROCKET ASY	4	V804-00-0020	BOLT, TORX 4	2
A356-00-0130	VALVE,CHECK	2	V186-00-0510	JOINT,PIPE	2	V804-00-0020	BOLT, TORX 4	4
A365-00-0050	CONNECTOR,CAP	2	V203-00-0041	BOLT,5	4	V804-00-0060	BOLT, TORX 4	2
A539-00-0440	COVER,MOTOR	2	V225-00-0370	BOLT,STUD 8	2	V805-00-0010	BOLT, TORX 5	4
A556-00-1800	DRUM, CLUTCH	4	V265-00-0550	NUT,8	4	V805-00-0160	BOLT, TORX 5	2
C022-00-0072	AUTO-OILER ASSEMBLY	2	V280-00-0000	NUT,WELD	2	X123-00-0231	BAR,GUIDE 35	6
C300-00-1170	GUARD, SPROCKET	4	V307-00-0520	WASHER,CIRCULAR 10	4	X223-00-0150	CHAIN,SAW	6
C309-00-0030	TENSIONER,CHAIN	4	V355-00-0900	COLLAR,8	4	X490-00-0510	SCABBARD,CHAIN	6
C320-00-0540	LEVER, BRAKE	4	V356-00-0430	COLLAR,10	4	X502-00-1060	LABEL,ECHO	2
C328-00-0340	BAND, BRAKE	4	V376-00-0450	SPACER	4	X502-00-1070	LABEL,ECHO	4
C334-00-0100	CONNECTOR, BRAKE	4	V450-00-2240	SPRING, COMPRESSION	4	X505-01-0220	LABEL,CAUTION	2
C345-00-0670	COVER,BRAKE	4	V450-00-2250	SPRING, COMPRESSION	2	X543-00-5090	LABEL,MODEL	2
C400-00-1650	HANDLE, FRONT	2	V452-00-0250	SPRING,TORSION	4	X602-00-0080	TOOL,WRENCH	6
C412-00-0740	GRIP, HANDLE	2	V452-00-1780	SPRING,TORSION	2	X605-00-0170	TOOL,L WRENCH	6
C490-00-0000	LOCKOUT	2	V452-00-1790	SPRING,TORSION	2			