

DEHUMIDIFIER

**DH 720**

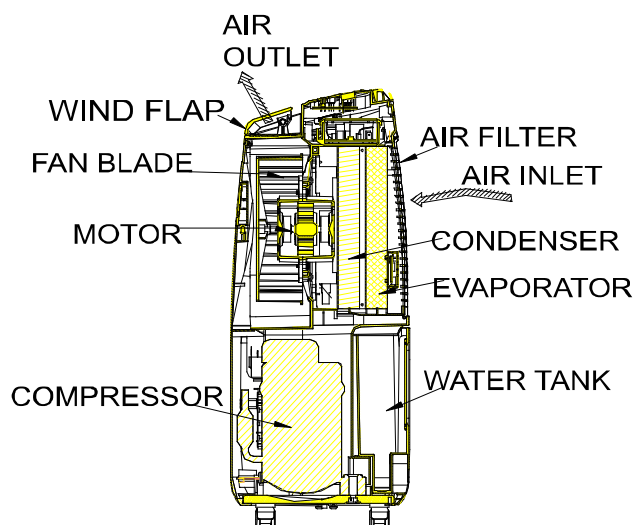

## FUNCTIONING PRINCIPLES



The dehumidifier controls humidity by forcing the excess of moisture to condense from the air into the unit as it passes over the cooling elements. Contact with this cold surface causes the moisture in the air to condense. This condensed water drains safely into the water tank. The dried air then passes through a warmed coil where it is warmed and reenters the room at slightly higher temperature.

## TECHNICAL DATA

Capacity (30°C/80%Rh)	l/24h	<b>20</b>	Refrigerant	<b>R134a</b>
Working range	°C / %Rh	<b>5-32 / 35-95</b>	Refrigerant mass.	kg
Net weight	kg	<b>11</b>	Tank capacity	l
Gross weight	kg	<b>12,4</b>	Power supply	V
Noise level	dB(A)	<b>48</b>	Frequency	Hz
Air flow	m <sup>3</sup> /h	<b>150</b>	Rated current	A
			Power consumption	W
				<b>390</b>

## PACKING

Package dimensions	mm	<b>385 x 260 x 583</b>
Device dimensions	mm	<b>336 x 210 x 569</b>
Pieces per Euro-pallet	n°	<b>27</b>
Pallet dimensions	mm	<b>800 x 1200 x 1850</b>

# COMPONENTS

Compressor	rotary
Fan	centrifugal
Water tank	5 l
Defrosting system	air flow
Hygrostat	electronic
Counter meter	-
Others	-

# ACCESSORIES

# WIRING DIAGRAM

